

### Description

- Time delay, high breaking capacity
- 5mm x 20mm physical size
- Ceramic tube, nickel plated brass endcap construction
- Optional axial leads are .032" x 1.5" copper tinned
- Designed to IEC 60127-2 (1A-6.3A)

ELECTRICAL CHARACTERISTICS										
In	1.5 In		2.1 In		2.75 In		4 In		10 In	
	min	max	min	max	min	max	min	max	min	max
<1A	60 min	30 min	250 ms	80 sec	50 ms	5 sec	5 ms	55 ms		
1A-3.15A	60 min	30 min	1 sec	80 sec	95 ms	5 sec	10 ms	100 ms		
4A-10A	60 min	30 min	1 sec	80 sec	150 ms	5 sec	20 ms	100 ms		
12.5A	--	30 min	1 sec	80 sec	150 ms	5 sec	20 ms	100 ms		

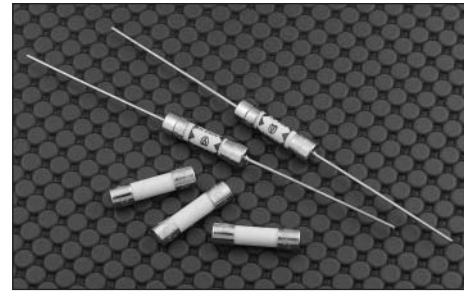

### Ordering

- Specify product code, option code and packaging code

### Agency Information

- UL Recognized Card: (1A-6.3A) Guide JDYX2, File E19180
- Semko Approval, 1A-6.3A
- VDE Approval, 1.25A-5A
- BSI Approval, 1.25A-6.3A
- IMQ Approval, 1.25A-6.3A
- MITI Approval, 1A-6.3A

### Dimensions

Drawing Not to Scale

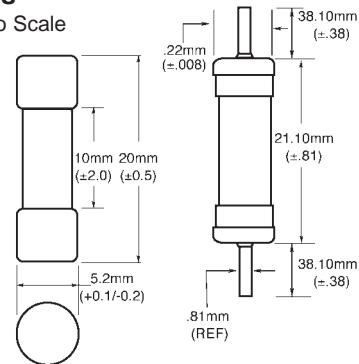

SPECIFICATIONS					
Product Code	Voltage Rating AC	Interrupting Rating at Rated Voltage (50Hz) AC	Typical DC Cold Resistance (ohms)*	Typical Melting I <sup>2</sup> t (A <sup>2</sup> Sec) AC†	Typical Voltage Drop (mV)‡
S505-500mA	250V	1500A	-	-	-
S505-800mA	250V	1500A	0.243	-	-
S505-1A	250V	1500A	0.117	0.74	170
S505-1.25A	250V	1500A	0.093	1.6	150
S505-1.6A	250V	1500A	0.061	3.5	130
S505-2A	250V	1500A	0.041	7.6	110
S505-2.5A	250V	1500A	0.030	14	100
S505-3.15A	250V	1500A	0.022	27	90
S505-4A	250V	1500A	0.015	52	85
S505-5A	250V	1500A	0.011	98	80
S505-6.3A	250V	1500A	0.008	197	75
S505-8A	250V	1500A	0.007	311	75
S505-10A	250V	1500A	0.006	397	72
S505-12.5A	250V	1000A	N/A	N/A	N/A

\* DC Cold Resistance (Measured at <10% of rated current)  
 † Typical Melting I<sup>2</sup>t (I<sup>2</sup>t was measured at listed interrupting rating and rated voltage)  
 ‡ Typical Voltage Drop (Voltage drop was measured at 20°C ambient temperature at rated current)

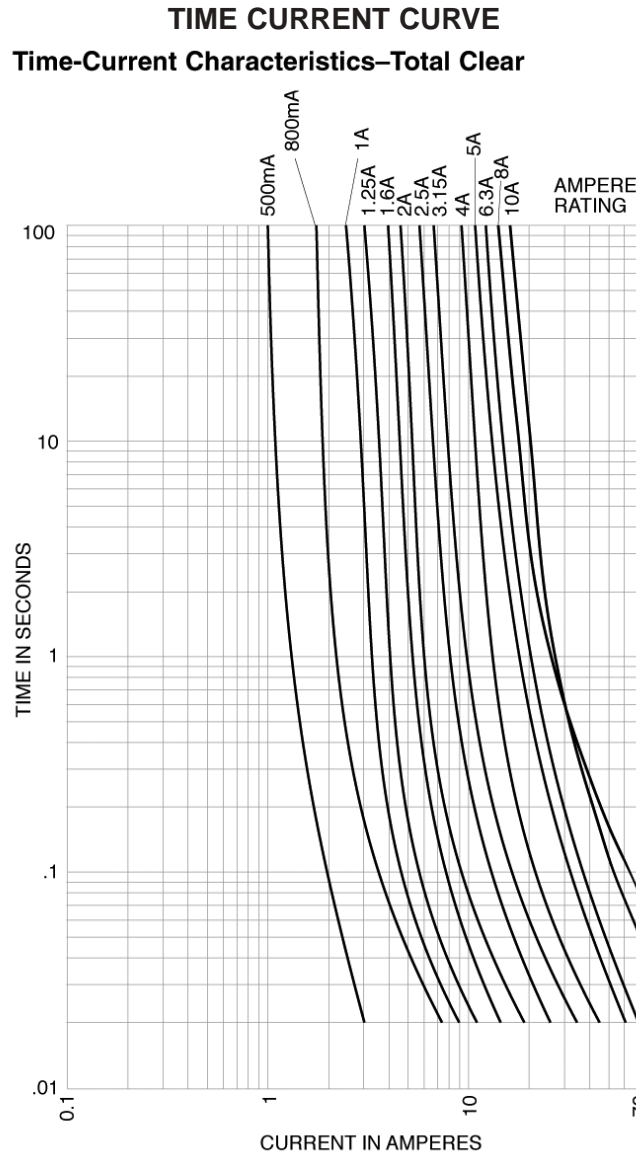

OPTION CODE	
Option Code	Description
V	Axial leads - copper tinned wire with nickel plated brass overcaps

PACKAGING CODE	
Packaging Code	Description
BK	100 pieces of fuses packed into a cardboard carton with flaps folded
BK1	1,000 pieces of fuses packed into a poly bag
TR2	1,500 pieces of fuses packed into tape on a reel